

# AMERICAN EQUINE INSURANCE GROUP

Applicant: \_\_\_\_\_

Location # \_\_\_\_\_

## WOOD / COAL BURNING STOVE REPORT

Type of Stove: \_\_\_\_\_

Stove installed by:  Owner  
 Licensed Contractor

Condition of Stove:  Good  
 Fair  
 Poor

What type of floor protection: \_\_\_\_\_

What type of wall protection: \_\_\_\_\_

Is there at least 1" inch air space between the stove wall and Protective shield and wall: Yes  No

Type of Chimney: \_\_\_\_\_

Last time Chimney was cleaned: \_\_\_\_\_

Condition of Chimney:  Good  
 Fair  
 Poor

Do all masonry chimneys have approved professionally installed inserts: Yes  No

Stove Pipe: Yes  No  How many elbows: \_\_\_\_\_

Pass through walls and/or ceilings? Yes  No

If yes, is a ventilated thimble being used: Yes  No

Is a heat saver being used: Yes  No

### Stove Clearances

1. Side of unit to nearest wall: \_\_\_\_\_ "
2. Rear of unit to wall \_\_\_\_\_ "
3. Top of stove pipe to ceiling: \_\_\_\_\_ "
4. Bottom of unit to floor: \_\_\_\_\_ "
5. Front of unit to front edge of floor protection: \_\_\_\_\_ "

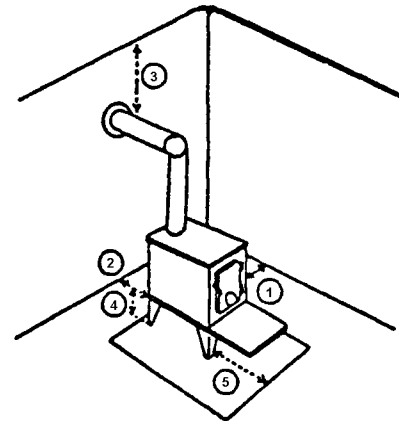

## MOBILE HOME TIE DOWN REPORT

Make of mobile home: \_\_\_\_\_

Model: \_\_\_\_\_ Length: \_\_\_\_\_

Year built: \_\_\_\_\_ Year installed: \_\_\_\_\_

### Minimum Tie Down Requirements

Length of Home	Frame Ties and Anchors per Side	Over Home Ties
Up to 40'	4	2
41' to 60'	6	3
61' to 82'	8	4

Does the Mobile Home meet the above minimum tie down requirements: Yes  No

Over Home ties buffered at corner if home does not include built-in strap.

